

NWA-8500

802.11a/g Ultra Thin Wireless Business Access Point

Quick Start Guide

Version 1.00
6/2007
Edition 1

CONTENTS

ENGLISH	1
DEUTSCH	19
ESPAÑOL	27
FRANÇAIS	35
ITALIANO	43
РУССКИЙ	51
SVENSKA	59
简体中文	65
繁體中文	71

The logo for ZyXEL, featuring the brand name in a bold, blue, sans-serif font. The 'Z' and 'X' are significantly larger and more stylized than the other letters.

Copyright © 2007. All rights reserved

Introduction

The NWA-8500 is an access point that receives power from a PoE (power over Ethernet) WLAN controller. The NWA-8500 does not require a power adapter or power cord. You can just deploy the NWA-8500 in your wireless network with a PoE wireless switch. Through the NWA-8500 (labeled **AP** in the following figure), wireless clients on the WLAN can access the Internet or the wired network.

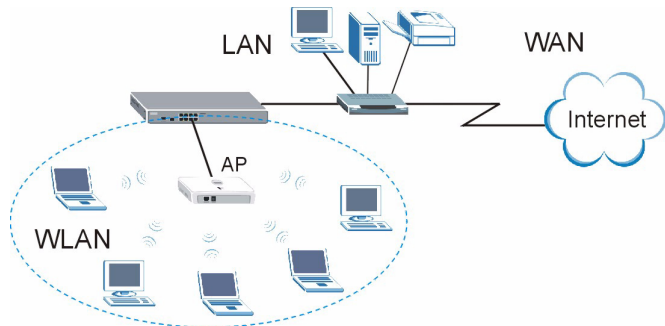

This guide shows you how to connect the NWA-8500 to a WLAN controller and hang your NWA-8500 on a wall.

1 Hardware Connections

Follow the steps below to connect your NWA-8500 for Internet access.

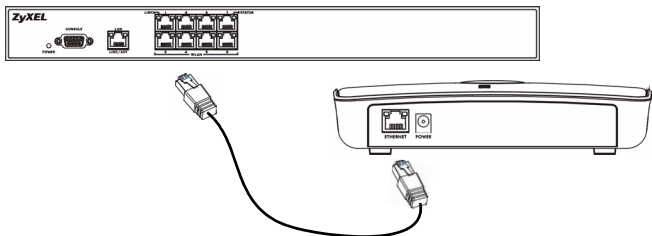

- 1 Use the included Ethernet cable to connect the **ETHERNET** port to a PoE WLAN controller's **WLAN** port. At the time of writing, you can connect only the NWA-8500 to the NXC-8160 model.

1.1 LEDs

Look at the LEDs (lights) on the NWA-8500.

The **PWR**, **LAN**, **WLAN 1** and **WLAN 2** LEDs are all on when the Ethernet port is properly connected. The **LAN**, **WLAN 1** and **WLAN 2** LEDs blink when there is traffic.

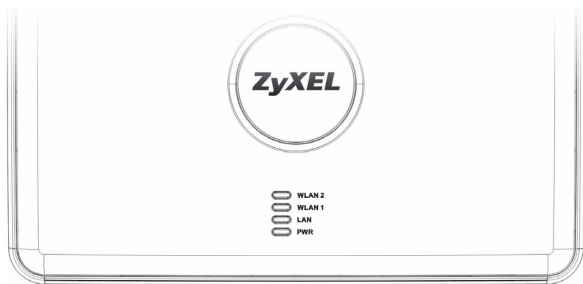



If none of the LEDs are on, check your connections, and inspect your cable for damage. Make sure that your wireless switch is powered on. If the LEDs are still off, contact your vendor.

2 Hardware Mounting

In general, the best location for the access point is at the center of your intended wireless coverage area. For better performance, mount the NWA-8500 in a place that is high up and free of obstructions.

2.1 Wall-mounted

Follow the steps to attach your NWA-8500 to a wall.



See [Product Specifications](#) for the size of screws to use and how far apart to place them.

- 1 Locate a high position on the wall that is free of obstructions.
- 2 Drill two holes for the screws.



Be careful to avoid damaging pipes or cables located inside the wall when drilling holes for the screws.

- 3 Do not insert the screws all the way into the wall. Leave a small gap of about 0.5 cm between the heads of the screws and the wall.
- 4 Make sure the screws are snugly fastened to the wall. They need to hold the weight of the NWA-8500 with the connection cables.
- 5 Align the holes on the back of the NWA-8500 with the screws on the wall. Hang the NWA-8500 on the screws.

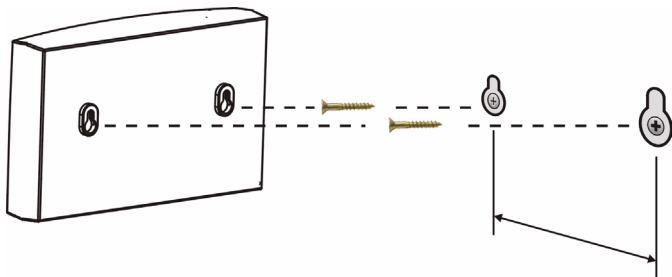

Product Specifications

Dimension	198.5 (W) x 138.5 (D) x 47.5 (H) mm
-----------	-------------------------------------

ENGLISH

Weight	400 g
Connector	One auto-negotiating, auto MDI/MDI-X 10/100 Mbps RJ-45 Ethernet port
Antenna	Internal antennas with dual-band support (2.4 GHz and 5 GHz)
Distance between the centers of the holes (for wall mounting) on the device's back.	140 mm
Recommended type of screws for wall-mounting	M4 Tap Screw (see the figure below)
Operating Temperature	0° C ~ 50° C
Operating Humidity	10% ~ 90% RH (non-condensing)
Approvals	EMC: FCC Class B, CE-EMC Class B, C-Tick Class B, VCCI Class B Safety: CSA International, CE EN60950-1

The following are dimensions of an M4 tap screw and masonry plug used for wall mounting. All measurements are in millimeters (mm).

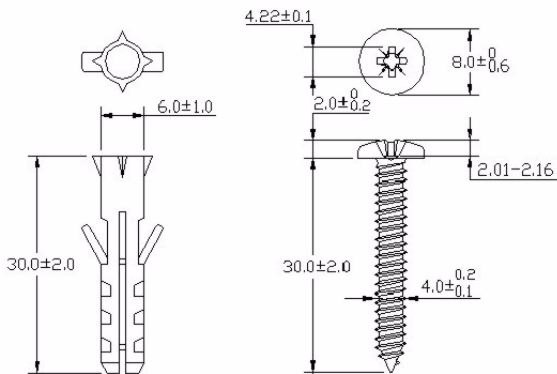

Certifications

Federal Communications Commission (FCC) Interference Statement

The device complies with Part 15 of FCC rules. Operation is subject to the following two conditions:

- This device may not cause harmful interference.
- This device must accept any interference received, including interference that may cause undesired operations.

This device has been tested and found to comply with the limits for a Class B digital device pursuant to Part 15 of the FCC Rules. These limits are designed to provide reasonable protection against harmful interference in a residential installation. This device generates, uses, and can radiate radio frequency energy, and if not installed and used in accordance with the instructions, may cause harmful interference to radio communications. However, there is no guarantee that interference will not occur in a particular installation.

If this device does cause harmful interference to radio/television reception, which can be determined by turning the device off and on, the user is encouraged to try to correct the interference by one or more of the following measures:

- Reorient or relocate the receiving antenna.
- Increase the separation between the equipment and the receiver.
- Connect the equipment into an outlet on a circuit different from that to which the receiver is connected.
- Consult the dealer or an experienced radio/TV technician for help.



FCC Radiation Exposure Statement

- This transmitter must not be co-located or operating in conjunction with any other antenna or transmitter.
- For operation within 5.15 ~ 5.25GHz frequency range, it is restricted to indoor environment.
- IEEE 802.11b or 802.11g operation of this product in the U.S.A. is firmware-limited to channels 1 through 11.
- To comply with FCC RF exposure compliance requirements, a separation distance of at least 20 cm must be maintained between the antenna of this device and all persons.

注意！

依據 低功率電波輻射性電機管理辦法

第十二條 經型式認證合格之低功率射頻電機，非經許可，公司、商號或使用者均不得擅自變更頻率、加大功率或變更原設計之特性及功能。

第十四條 低功率射頻電機之使用不得影響飛航安全及干擾合法通信；經發現有干擾現象時，應立即停用，並改善至無干擾時方得繼續使用。

前項合法通信，指依電信規定作業之無線電信。低功率射頻電機須忍受合法通信或工業、科學及醫療用電波輻射性電機設備之干擾。

在 5250MHz~5350MHz 頻帶內操作之無線資訊傳輸設備，限於室內使用。

Notices

Changes or modifications not expressly approved by the party responsible for compliance could void the user's authority to operate the equipment.

This device has been designed for the WLAN 2.4 GHz and 5 GHz networks throughout the EC region and Switzerland, with restrictions in France.

This Class B digital apparatus complies with Canadian ICES-003.

Cet appareil numérique de la classe B est conforme à la norme NMB-003 du Canada.

Viewing Certifications

- 1 Go to <http://www.zyxel.com>.
- 2 Select your product on the ZyXEL home page to go to that product's page.
- 3 Select the certification you wish to view from this page.

Safety Warnings



For your safety, be sure to read and follow all warning notices and instructions.

- Do NOT use this product near water, for example, in a wet basement or near a swimming pool.
- Do NOT expose your device to dampness, dust or corrosive liquids.
- Do NOT store things on the device.
- Do NOT install, use, or service this device during a thunderstorm. There is a remote risk of electric shock from lightning.
- Connect ONLY suitable accessories to the device.
- Do NOT open the device or unit. Opening or removing covers can expose you to dangerous high voltage points or other risks. ONLY qualified service personnel should service or disassemble this device. Please contact your vendor for further information.
- Make sure to connect the cables to the correct ports.
- Place connecting cables carefully so that no one will step on them or stumble over them.
- Always disconnect all cables from this device before servicing or disassembling.
- Do not use the device outside, and make sure all the connections are indoors. There is a remote risk of electric shock from lightning.
- Do NOT obstruct the device ventilation slots, as insufficient airflow may harm your device.
- Antenna Warning! This device meets ETSI and FCC certification requirements when using the included antenna(s). Only use the included antenna(s).

- If you wall mount your device, make sure that no electrical lines, gas or water pipes will be damaged.
- The PoE (Power over Ethernet) devices that supply or receive power and their connected Ethernet cables must all be completely indoors.

This product is recyclable. Dispose of it properly.



Warranty

ZyXEL Limited Warranty

ZyXEL warrants to the original end user (purchaser) that this product is free from any defects in materials or workmanship for a period of up to two years from the date of purchase. During the warranty period, and upon proof of purchase, should the product have indications of failure due to faulty workmanship and/or materials, ZyXEL will, at its discretion, repair or replace the defective products or components without charge for either parts or labor, and to whatever extent it shall deem necessary to restore the product or

components to proper operating condition. Any replacement will consist of a new or re-manufactured functionally equivalent product of equal or higher value, and will be solely at the discretion of ZyXEL. This warranty shall not apply if the product has been modified, misused, tampered with, damaged by an act of God, or subjected to abnormal working conditions.

Note

Repair or replacement, as provided under this warranty, is the exclusive remedy of the purchaser. This warranty is in lieu of all other warranties, express or implied, including any implied warranty of merchantability or fitness for a particular use or purpose. ZyXEL shall in no event be held liable for indirect or consequential damages of any kind to the purchaser.

To obtain the services of this warranty, contact ZyXEL's Service Center for your Return Material Authorization number (RMA). Products must be returned Postage Prepaid. It is recommended that the unit be insured when shipped. Any returned products without proof of purchase or those with an out-dated warranty will be repaired or replaced (at the discretion of ZyXEL) and the customer will be billed for parts and labor. All repaired or replaced products will be shipped by ZyXEL to the corresponding return address, Postage Paid. This warranty gives you specific legal rights, and you may also have other rights that vary from country to country.

Related Documentation

Please go to <http://www.zyxel.com> for product news, firmware, documentation,

and other support materials.

Registration

Register your product online to receive e-mail notices of firmware upgrades and information at www.zyxel.com for global products, or at www.us.zyxel.com for North American products.

User Guide Feedback

Help us help you. E-mail all User Guide-related comments, questions or suggestions for improvement to techwriters@zyxel.com.tw or send regular mail to The Technical Writing Team, ZyXEL Communications Corp., 6 Innovation Road II, Science-Based Industrial Park, Hsinchu, 300, Taiwan. Thank you.

Copyright

Copyright © 2007 by ZyXEL Communications Corporation.

The contents of this publication may not be reproduced in any part or as a whole, transcribed, stored in a retrieval system, translated into any language, or transmitted in any form or by any means, electronic, mechanical, magnetic, optical, chemical, photocopying, manual, or otherwise, without the prior written permission of ZyXEL Communications Corporation.

Published by ZyXEL Communications Corporation. All rights reserved.

Disclaimer

ZyXEL does not assume any liability arising out of the application or use of any products, or software described herein. Neither does it convey any license under its patent rights nor the patent rights of others. ZyXEL further reserves the right to make changes in any products described herein without notice. This publication is subject to change without notice.

Trademarks

ZyNOS (ZyXEL Network Operating System) is a registered trademark of ZyXEL Communications, Inc. Other trademarks mentioned in this publication are used for identification purposes only and may be properties of their respective owners.

Customer Support

Please have the following information ready when you contact customer support.

- Product model and serial number.

- Warranty Information.
- Date that you received your device.
- Brief description of the problem and the steps you took to solve it.

“+” is the (prefix) number you dial to make an international telephone call.

Corporate Headquarters (Worldwide)

- Support E-mail: support@zyxel.com.tw
- Sales E-mail: sales@zyxel.com.tw
- Telephone: +886-3-578-3942
- Fax: +886-3-578-2439
- Web: www.zyxel.com, www.europe.zyxel.com
- FTP: ftp.zyxel.com, ftp.europe.zyxel.com
- Regular Mail: ZyXEL Communications Corp., 6 Innovation Road II, Science Park, Hsinchu 300, Taiwan

Costa Rica

- Support E-mail: soporte@zyxel.co.cr
- Sales E-mail: sales@zyxel.co.cr
- Telephone: +506-2017878
- Fax: +506-2015098
- Web: www.zyxel.co.cr
- FTP: ftp.zyxel.co.cr
- Regular Mail: ZyXEL Costa Rica, Plaza Roble Escazú, Etapa El Patio, Tercer Piso, San José, Costa Rica

Czech Republic

- E-mail: info@cz.zyxel.com
- Telephone: +420-241-091-350
- Fax: +420-241-091-359
- Web: www.zyxel.cz
- Regular Mail: ZyXEL Communications, Czech s.r.o., Modranská 621, 143 01 Praha 4 - Modrany, Česká Republika

Denmark

- Support E-mail: support@zyxel.dk
- Sales E-mail: sales@zyxel.dk
- Telephone: +45-39-55-07-00
- Fax: +45-39-55-07-07
- Web: www.zyxel.dk
- Regular Mail: ZyXEL Communications A/S, Columbusvej, 2860 Soeborg, Denmark

Finland

- Support E-mail: support@zyxel.fi
- Sales E-mail: sales@zyxel.fi
- Telephone: +358-9-4780-8411

- Fax: +358-9-4780-8448
- Web: www.zyxel.fi
- Regular Mail: ZyXEL Communications Oy, Malminkaari 10, 00700 Helsinki, Finland

France

- E-mail: info@zyxel.fr
- Telephone: +33-4-72-52-97-97
- Fax: +33-4-72-52-19-20
- Web: www.zyxel.fr
- Regular Mail: ZyXEL France, 1 rue des Vergers, Bat. 1 / C, 69760 Limonest, France

Germany

- Support E-mail: support@zyxel.de
- Sales E-mail: sales@zyxel.de
- Telephone: +49-2405-6909-69
- Fax: +49-2405-6909-99
- Web: www.zyxel.de
- Regular Mail: ZyXEL Deutschland GmbH., Adenauerstr. 20/A2 D-52146, Wuerselen, Germany

Hungary

- Support E-mail: support@zyxel.hu
- Sales E-mail: info@zyxel.hu
- Telephone: +36-1-3361649
- Fax: +36-1-3259100
- Web: www.zyxel.hu
- Regular Mail: ZyXEL Hungary, 48, Zoldlomb Str., H-1025, Budapest, Hungary

India

- Support E-mail: support@zyxel.in
- Sales E-mail: sales@zyxel.in
- Telephone: +91-11-30888144 to +91-11-30888153
- Fax: +91-11-30888149, +91-11-26810715
- Web: <http://www.zyxel.in>
- Regular Mail: India - ZyXEL Technology India Pvt Ltd., II-Floor, F2/9 Okhla Phase -1, New Delhi 110020, India

Japan

- Support E-mail: support@zyxel.co.jp
- Sales E-mail: zyp@zyxel.co.jp
- Telephone: +81-3-6847-3700
- Fax: +81-3-6847-3705
- Web: www.zyxel.co.jp
- Regular Mail: ZyXEL Japan, 3F, Office T&U, 1-10-10 Higashi-Gotanda, Shina-

gawa-ku, Tokyo 141-0022, Japan

Kazakhstan

- Support: <http://zyxel.kz/support>
- Sales E-mail: sales@zyxel.kz
- Telephone: +7-3272-590-698
- Fax: +7-3272-590-689
- Web: www.zyxel.kz
- Regular Mail: ZyXEL Kazakhstan, 43 Dostyk Ave., Office 414, Dostyk Business Centre, 050010 Almaty, Republic of Kazakhstan

Malaysia

- Support E-mail: support@zyxel.com.my
- Sales E-mail: sales@zyxel.com.my
- Telephone: +603-8076-9933
- Fax: +603-8076-9833
- Web: <http://www.zyxel.com.my>
- Regular Mail: ZyXEL Malaysia Sdn Bhd., 1-02 & 1-03, Jalan Kenari 17F, Bandar Puchong Jaya, 47100 Puchong, Selangor Darul Ehsan, Malaysia

North America

- Support E-mail: support@zyxel.com
- Sales E-mail: sales@zyxel.com
- Telephone: +1-800-255-4101, +1-714-632-0882
- Fax: +1-714-632-0858
- Web: www.us.zyxel.com
- FTP: <ftp.us.zyxel.com>
- Regular Mail: ZyXEL Communications Inc., 1130 N. Miller St., Anaheim, CA 92806-2001, U.S.A.

Norway

- Support E-mail: support@zyxel.no
- Sales E-mail: sales@zyxel.no
- Telephone: +47-22-80-61-80
- Fax: +47-22-80-61-81
- Web: www.zyxel.no
- Regular Mail: ZyXEL Communications A/S, Nils Hansens vei 13, 0667 Oslo, Norway

Poland

- E-mail: info@pl.zyxel.com
- Telephone: +48-22-333 8250
- Fax: +48-22-333 8251
- Web: www.pl.zyxel.com
- Regular Mail: ZyXEL Communications, ul. Okrzei 1A, 03-715 Warszawa, Poland

Russia

- Support: <http://zyxel.ru/support>
- Sales E-mail: sales@zyxel.ru
- Telephone: +7-095-542-89-29
- Fax: +7-095-542-89-25
- Web: www.zyxel.ru
- Regular Mail: ZyXEL Russia, Ostrovityanova 37a Str., Moscow 117279, Russia

Singapore

- Support E-mail: support@zyxel.com.sg
- Sales E-mail: sales@zyxel.com.sg
- Telephone: +65-6899-6678
- Fax: +65-6899-8887
- Web: <http://www.zyxel.com.sg>
- Regular Mail: ZyXEL Singapore Pte Ltd., No. 2 International Business Park, The Strategy #03-28, Singapore 609930

Spain

- Support E-mail: support@zyxel.es
- Sales E-mail: sales@zyxel.es
- Telephone: +34-902-195-420
- Fax: +34-913-005-345
- Web: www.zyxel.es
- Regular Mail: ZyXEL Communications, Arte, 21 5ª planta, 28033 Madrid, Spain

Sweden

- Support E-mail: support@zyxel.se
- Sales E-mail: sales@zyxel.se
- Telephone: +46-31-744-7700
- Fax: +46-31-744-7701
- Web: www.zyxel.se
- Regular Mail: ZyXEL Communications A/S, Sjöporten 4, 41764 Göteborg, Sweden

Thailand

- Support E-mail: support@zyxel.co.th
- Sales E-mail: sales@zyxel.co.th
- Telephone: +662-831-5315
- Fax: +662-831-5395
- Web: <http://www.zyxel.co.th>
- Regular Mail: ZyXEL Thailand Co., Ltd., 1/1 Moo 2, Ratchaphruk Road, Bangrak-Noi, Muang, Nonthaburi 11000, Thailand.

Ukraine

- Support E-mail: support@ua.zyxel.com
- Sales E-mail: sales@ua.zyxel.com
- Telephone: +380-44-247-69-78
- Fax: +380-44-494-49-32
- Web: www.ua.zyxel.com
- Regular Mail: ZyXEL Ukraine, 13, Pimonenko Str., Kiev 04050, Ukraine

United Kingdom

- Support E-mail: support@zyxel.co.uk
- Sales E-mail: sales@zyxel.co.uk
- Telephone: +44-1344-303044, 08707-555779 (UK only)
- Fax: +44-1344-303034
- Web: www.zyxel.co.uk
- FTP: [ftp.zyxel.co.uk](ftp://ftp.zyxel.co.uk)
- Regular Mail: ZyXEL Communications UK Ltd., 11 The Courtyard, Eastern Road, Bracknell, Berkshire RG12 2XB, United Kingdom (UK)

Einführung

Der NWA-8500 ist ein Access-Point (AP), der über einen PoE (Power-over-Ethernet) WLAN-Controller mit Strom versorgt wird. Der NWA-8500 erfordert keinen Netzadapter oder Stromkabel. Sie können den NWA-8500 in Ihrem Drahtlosnetzwerk einfach mit einem PoE-Wireless-Switch verwenden. Mit dem NWA-8500 (in der folgenden Abbildung **AP** bezeichnet) können Wireless-Clients im WLAN auf das Internet oder auf das Drahtlosnetzwerk zugreifen.

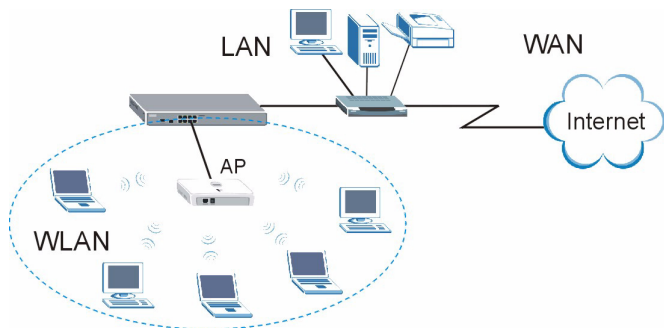

In dieser Anleitung wird beschrieben, wie der NWA-8500 an einen WLAN-Controller angeschlossen wird und wie der NWA-8500 an einer Wand montiert wird.

1 Anschließen der Hardware

Führen Sie die unten beschriebenen Schritte aus, um den NWA-8500 für den Internetzugang anzuschließen.

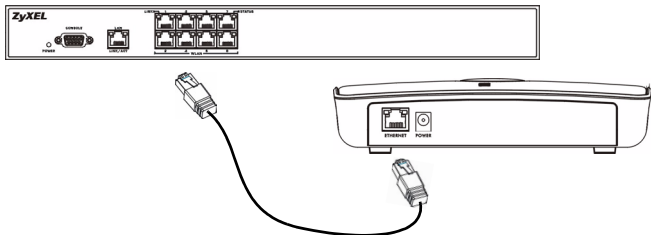

- 1 Verbinden Sie mit einem Ethernet-Kabel den **ETHERNET**-Port mit dem **WLAN**-Port eines PoE WLAN-Controllers. Zum Zeitpunkt der Druckstellung kann nur der NWA-8500 mit dem Modell NXC-8160 verbunden werden.

1.1 LED-Anzeigen

Der NWA-8500 verfügt über eine Reihe von LED-Anzeigen.

Wenn der Ethernet-Port richtig angeschlossen ist, leuchten alle LED-Anzeigen (**PWR**, **LAN**, **WLAN 1** und **WLAN 2**). Wenn Datenverkehr vorhanden ist, blinken die LED-Anzeigen **LAN**, **WLAN 1** und **WLAN 2**.

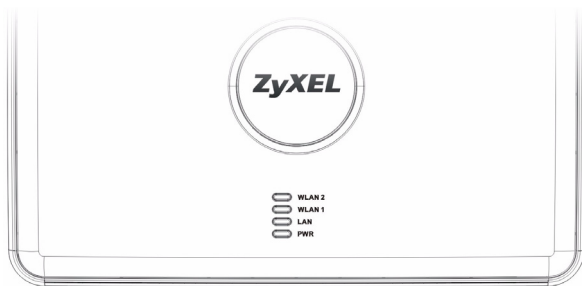

Wenn keine der LEDs leuchtet, prüfen Sie noch einmal alle Kabelverbindungen. Stellen Sie sicher, dass der Wireless-Switch eingeschaltet ist. Wenn die LED-Anzeigen weiterhin nicht leuchten, wenden Sie sich an Ihren Händler.

2 Aufstellen/Montieren der Hardware

Die günstigste Position für den AP ist im allgemeinen der Mittelpunkt des Bereichs, der für die Drahtlosverbindungen vorgesehen ist. Eine bessere Reichweite wird erzielt, wenn Sie den NWA-8500 an einem höher gelegenen Ort montieren, der frei von Hindernissen zu den anderen Geräten ist.

2.1 An einer Wand montiert

Führen Sie die nachfolgenden Schritte aus, um den NWA-8500 an einer Wand zu montieren.

Eine Angabe der zu verwendenden Schrauben und des Schraubabstands finden Sie in den [Produktspezifikationen](#).

- 1 Verwenden Sie eine Stelle an einer Wand, die sehr hoch liegt und an der die Datenübertragung nicht durch Hindernisse gestört werden kann.
- 2 Bohren Sie die zwei Löcher für die Schrauben.

Achten Sie beim Bohren der Löcher darauf, keine unter der Wand verlegten Kabel oder Rohre zu beschädigen.

- 3 Drehen Sie die Schrauben nicht ganz in die Wand ein. Lassen Sie einen kleinen Abstand von ca. 0,5 cm zwischen den Schraubköpfen und der Wand.
- 4 Stellen Sie sicher, dass die Schrauben fest in der Wand befestigt sind. Sie müssen das Gewicht des NWA-8500 und der Anschlusskabel tragen können.
- 5 Richten Sie die Löcher an der Rückseite des NWA-8500 an den Schrauben in der Wand aus. Hängen Sie den NWA-8500 an die Schrauben.

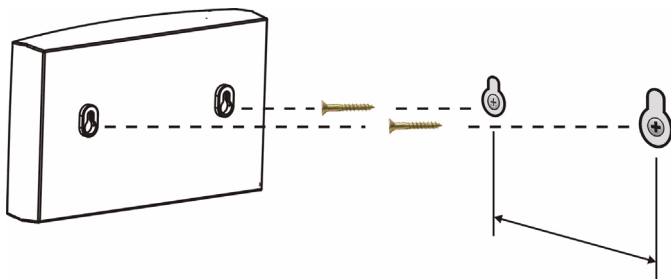

Produktspezifikationen

Abmessungen	198,5 x 138,5 x 47,5 mm (B x T x H)	
Gewicht	400 g	
Anschlüsse	Ein RJ-45-Ethernet-Port (Auto-Negotiating, Auto MDI/MDI-X, 10/100 Mbps)	
Antenne	Interne Antennen mit Dualband-Unterstützung (2,4 GHz und 5 GHz)	
Abstand zwischen den Mittelpunkten der Schraublöcher an der Geräterückseite (für die Wandmontage).	140 mm	
Empfohlene Schraubentypen für die Wandmontage	M4-Gewindeschraube (siehe Abbildung nächste Seite)	
Temperatur bei Betrieb	0 °C bis 50 °C	
Luftfeuchtigkeit bei Betrieb	10 % bis 90 % RH (nicht-kondensierend)	
Kennzeichnungen	EMC: FCC Klasse B, CE-EMC Klasse B, C-Tick Klasse B, VCCI Klasse B Sicherheit: CSA International, CE EN60950-1	

Abmessungen einer M4-Gewindeschraube und eines Dübels für die Wandmontage. Alle Angaben in Millimeter (mm).

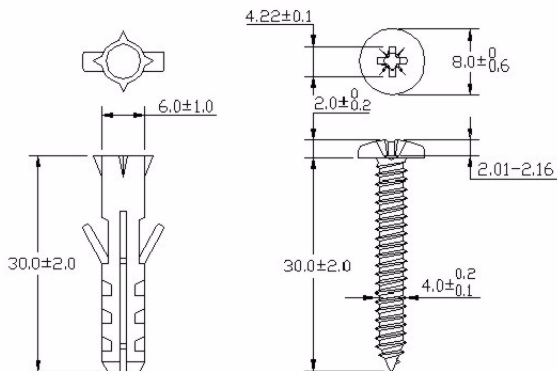

Vorgehensweise zum Aufrufen einer Produktzertifizierung

- 1 Gehen Sie auf www.zyxel.com.
- 2 Wählen Sie Ihr Produkt aus der Auswahlliste auf der ZyXEL Homepage aus, um die Seite des entsprechenden Produkts aufzurufen.
- 3 Wählen Sie die Zertifizierung, die Sie von dieser Seite aus aufrufen möchten

Introducción

El NWA-8500 es un punto de acceso que recibe corriente desde un controlador WAN PoE (power over Ethernet). El NWA-8500 no necesita un adaptador de corriente o cable de alimentación. Simplemente despliegue el NWA-8500 en su red inalámbrica con un switch inalámbrico PoE. A través del NWA-8500 (etiquetado como **AP** en la figura siguiente), los clientes inalámbricos de la WLAN pueden acceder a Internet o a la red con cables.

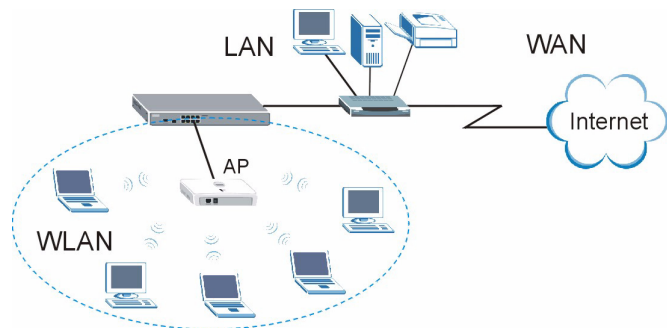

Esta guía le muestra cómo conectar el NWA-8500 a un controlador WLAN y colgar su NWA-8500 en una pared.

1 Conexiones del hardware

Siga estos pasos para conectar su NWA-8500 para el acceso a Internet.

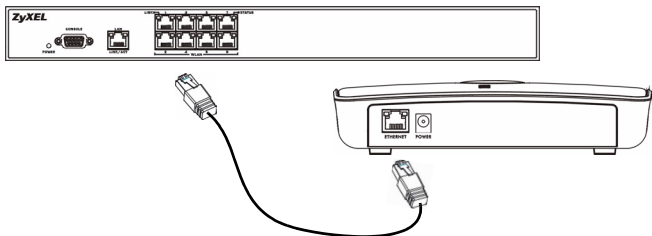

- 1 Utilice el cable Ethernet incluido para conectar el puerto **ETHERNET** a un puerto **WLAN** del controlador PoE WLAN. En el momento de esta publicación, sólo puede conectar el NWA-8500 al modelo NXC-8160.

1.1 LEDs

Mire los LEDs (luces) del NWA-8500.

Los LEDs **PWR**, **LAN**, **WLAN 1** y **WLAN 2** están todos encendidos cuando el puerto Ethernet está correctamente conectado. Los LEDs **LAN**, **WLAN 1** y **WLAN 2** parpadean cuando hay tráfico.

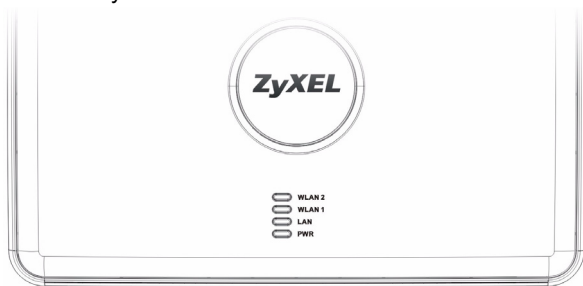

Si ninguno de los LEDs está encendido, verifique sus conexiones y compruebe si el cable está dañado. Asegúrese de que el switch inalámbrico esté encendido. Si los LEDs continúan apagados, contacte con su vendedor.

2 Montaje del hardware

En general, la mejor ubicación para el punto de acceso es en el centro del área de cobertura. Para un mejor rendimiento, monte el NWA-8500 en un lugar bien alto y libre de obstáculos.

2.1 Montaje en pared

Siga estos pasos para montar su NWA-8500 en una pared.



Consulte [Especificaciones del producto](#) para el tamaño de los tornillos a usar y la distancia al colocarlos.

- 1 Localice una posición alta en la pared libre de obstáculos.
 - 2 Perfore dos agujeros para los tornillos.
-



Procure evitar dañar los tubos o cables situados en el interior de la pared al perforar los agujeros para los tornillos.

- 3 No inserte los tornillos hasta el fondo en la pared. Deje un pequeño hueco de unos 0,5 cm entre las cabezas de los tornillos y la pared.
 - 4 Asegúrese de que los tornillos estén perfectamente apretados en la pared. Deberán soportar el peso del NWA-8500 con los cables de conexión.
-

- 5** Alinee los agujeros en la parte posterior del NWA-8500 con los tornillos en la pared. Cuelgue el NWA-8500 en los tornillos.

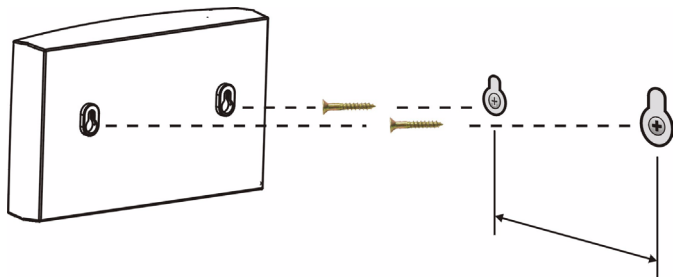

Especificaciones del producto

Dimensiones	198.5 (An) x 138.5 (F) x 47.5 (Al) mm	
Peso	400 g	
Conector	Un puerto Ethernet RJ-45 con autonegociación, MDI/MDI-X automático 10/100 Mbps	
Antena	Antenas internas con soporte de banda dual (2.4 GHz y 5 GHz)	
Distancia entre los centros de los agujeros (para montaje en pared) en la parte trasera del dispositivo.	140 mm	
Tipo de tornillos recomendado para el montaje en pared	Tornillo con cabeza M4 (ver figura siguiente)	

Temperatura de operación	0°C ~ 50°C
Humedad de operación	10% ~ 90% RH (no condensada)
Aprobaciones	EMC: FCC Clase B, CE-EMC Clase B, C-Tick Clase B, VCCI Clase B Seguridad: CSA Internacional, CE EN60950-1

Estas son las dimensiones de un tornillo con cabeza M4 y del taco de obra usado para el montaje en pared. Todas las medidas están en milímetros (mm).

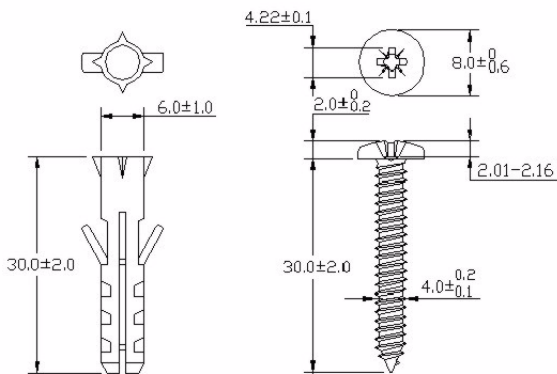

Procedimiento para ver las certificaciones de un producto

1 Vaya a www.zyxel.com.

- 2** Seleccione el producto que desea en el cuadro de lista desplegable que se encuentra en la página principal de ZyXEL para obtener acceso a la página de dicho producto.
- 3** Seleccione la certificación que desea ver en esta página.

Introduction

Le NWA-8500 est un point d'accès qui reçoit l'alimentation à partir d'un contrôleur WLAN PoE (power over Ethernet). Le NWA-8500 ne nécessite ni un adaptateur d'alimentation, ni un cordon d'alimentation. Il vous suffit de déployer le NWA-8500 dans votre réseau sans fil avec un commutateur PoE sans fil. A travers le NWA-8500 (portant la marque **AP** dans la figure suivante), les clients sans fil sur le WLAN peuvent accéder à Internet ou au réseau câblé.

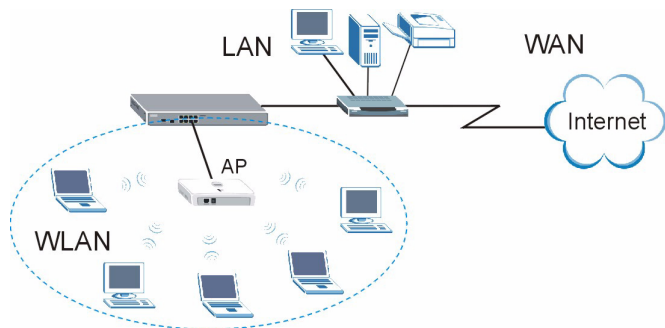

Ce guide vous montre comment connecter le NWA-8500 à un contrôleur WLAN et suspendre votre NWA-8500 à un mur.

1 Connexions matérielles

Suivez les étapes ci-dessous pour connecter votre NWA-8500 pour permettre l'accès à Internet.

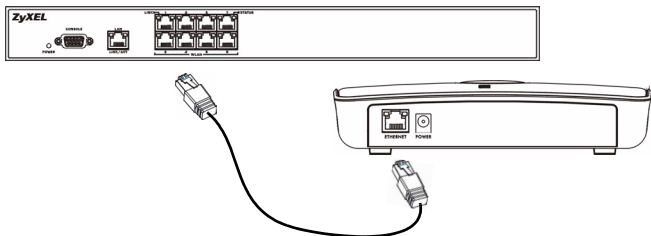

- 1 Utilisez le câble Ethernet inclus pour connecter le port **ETHERNET** à un port WLAN du contrôleur PoE **WLAN**. Au moment de la rédaction, vous pouvez uniquement connecter le NWA-8500 au modèle NXC-8160.

1.1 LEDs

Observez les LEDs (voyants) sur le NWA-8500.

Les LEDs **PWR**, **LAN**, **WLAN 1** et **WLAN 2** sont toutes allumées quand le port Ethernet est correctement connecté. Les LEDs **LAN**, **WLAN 1** et **WLAN 2** clignotent lorsqu'il y a du trafic.

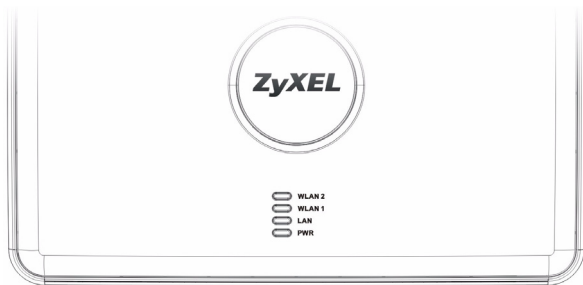

Si aucune des LEDs n'est allumée, vérifiez vos connexions, et vérifiez si votre câble n'est pas endommagé. Assurez-vous que votre commutateur sans fil est allumé. Si les LEDs sont toujours éteintes, contactez votre vendeur.

2 Fixation du matériel

En général, le meilleur emplacement pour le point d'accès est au centre de votre zone de couverture sans fil. Pour obtenir de meilleures performances, fixez le NWA-8500 sur un point élevé et sans obstructions.

2.1 Montage mural

Suivez les étapes pour fixer votre NWA-8500 à un mur.



Voir [Spécifications du produit](#) pour la taille des vis à utiliser et l'espacement entre celles-ci.

- 1 Repérez une position élevée sur le mur ne comportant pas d'obstructions.
- 2 Percez deux trous pour les vis.



Faites attention à ne pas endommager les tuyaux ou les fils encastrés dans le mur lorsque vous percez les trous pour les vis.

- 3 Ne vissez pas les vis sur toute leur longueur dans le mur. Laissez un petit espace d'environ 0,5 cm entre les têtes des vis et le mur.
- 4 Vérifiez que les vis sont bien fixées sur le mur. Elles doivent pouvoir supporter le poids du NWA-8500 avec les câbles de connexion.

- 5** Alignez les trous au dos du NWA-8500 avec les vis sur le mur. Suspendez le NWA-8500 aux vis.

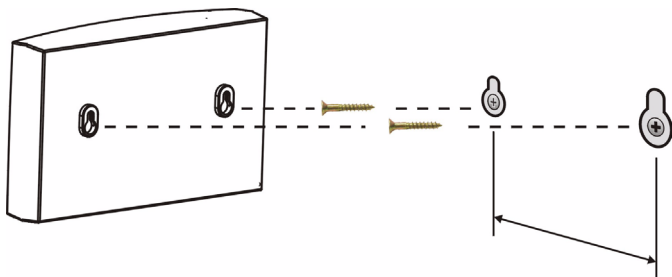

Spécifications du produit

Dimensions	198,5(l) x 138,5(P) x 47,5(H) mm	
Poids	400 g	
Connecteur	Un port Ethernet RJ-45 en auto-négociation, auto MDI/MDI-X 10/100 Mbps	
Antenne	Antennes internes avec support double bande (2,4 GHz et 5 GHz)	
Distance entre les centres des trous (pour la fixation murale) au dos de l'appareil.	140 mm	
Type de vis recommandé pour la fixation murale	Vis-taraud M4 (voir la figure ci-dessous).	

Température de fonctionnement	0°C ~ 50°C
Humidité de fonctionnement	10% ~ 90% RH (sans condensation)
Homologations	EMC : FCC Classe B, CE-EMC Classe B, C-Tick Classe B, VCCI Classe B Sécurité : CSA International, CE EN60950-1

Voici les dimensions d'une vis-taraud M4 et d'une cheville pour la fixation murale. Toutes les mesures sont en millimètres (mm).

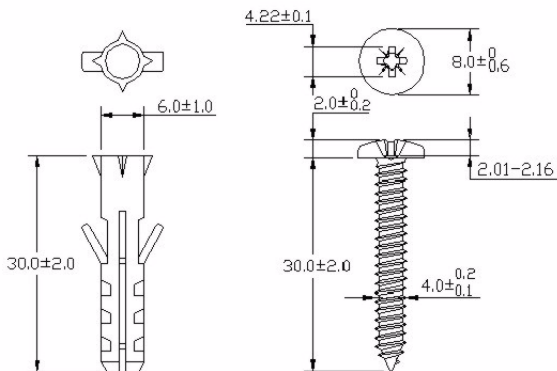

Procédure permettant de consulter une(les) Certification(s) du Produit

- 1** Connectez vous sur www.zyxel.com.
- 2** Sélectionnez votre produit dans la liste déroulante se trouvant sur la page d'accueil ZyXEL pour accéder à la page du produit concerné.
- 3** Sélectionnez sur cette page la certification que vous voulez consulter.

Introduzione

Il NWA-8500 è un Access Point che viene alimentato da un controller WLAN PoE (power over Ethernet). Il NWA-8500 non richiede la presenza di un alimentatore né di un cavo di alimentazione. Il NWA-8500 può essere inserito nella rete wireless solo con uno switch wireless PoE. Tramite il NWA-8500 (etichettato **AP** nella figura seguente), i client wireless della WLAN possono accedere a Internet sulla rete cablata.

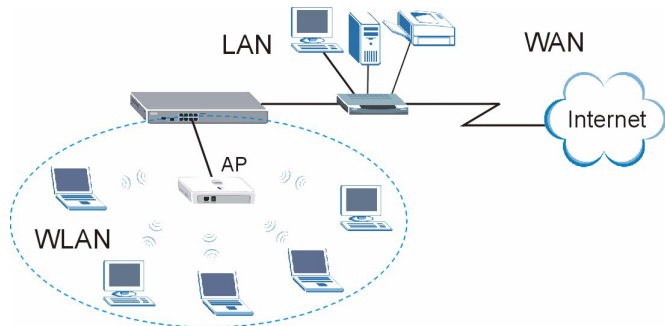

In questa guida viene mostrato come collegare il NWA-8500 a un controller WLAN e fissare il NWA-8500 a una parete.

1 Collegamenti hardware

Attenersi alla procedura seguente per collegare NWA-8500 per l'accesso a Internet.

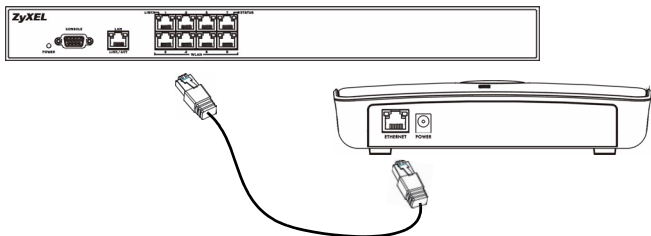

- 1 Utilizzare il cavo Ethernet fornito a corredo per collegare la porta **ETHERNET** alla porta **WLAN** di un controller WLAN PoE. Nel momento della scrittura di questo documento è possibile collegare il NWA-8500 solo al modello NXC-8160.

1.1 LED

Osservare i LED (spie) presenti sul NWA-8500.

I LED **PWR**, **LAN**, **WLAN 1** e **WLAN 2** sono tutti accesi quando la porta Ethernet è collegata correttamente. I LED **LAN**, **WLAN 1** e **WLAN 2** lampeggiano quando c'è traffico.

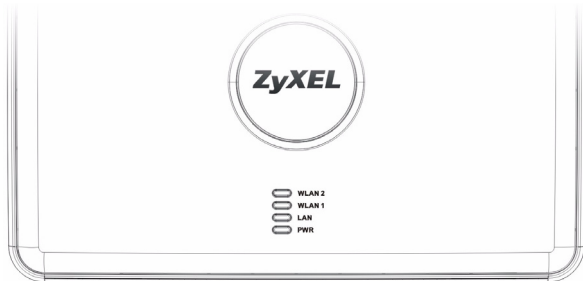

Se nessuno dei LED è acceso, verificare i collegamenti e controllare che il cavo non presenti alcun danno. Verificare che lo switch wireless sia acceso. Se i LED restano ancora spenti, contattare il rivenditore.

2 Montaggio dell'hardware

In generale, la posizione migliore per il punto di accesso è al centro dell'area di copertura wireless. Per prestazioni ottimali, montare il dispositivo in posizione sopraelevata, senza ostacoli. Per prestazioni ottimali, montare il NWA-8500 in posizione sopraelevata, senza ostacoli.

2.1 Montaggio a muro

Seguire i seguenti punti per applicare ZyAIR NWA-8500 ad una parete.



Vedere [Caratteristiche tecniche del prodotto](#) per le dimensioni delle viti del da utilizzare e per come distanziarle.

- 1 Individuare una posizione elevata sul muro che sia esente da ostacoli.
- 2 Praticare due fori per le viti.



Fare attenzione a non danneggiare tubazioni o cavi che si trovano nel muro quando si eseguono i fori per le viti con il trapano.

- 3 Non inserire le viti fino in fondo nella parete. Lasciare un piccolo spazio di circa 0,5 cm tra la testa delle viti e il muro.
- 4 Verificare che le viti siano fissate alla parete in modo sicuro. Esse devono sostenere il peso del NWA-8500 insieme ai cavi di collegamento.

- 5** Allineare i fori presso la parte posteriore di ZyAIR NWA-8500 con le viti sulla parete. Appendere il NWA-8500 sulle viti.

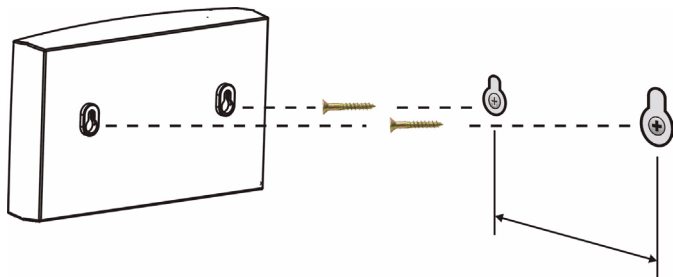

Caratteristiche tecniche del prodotto

Dimensione	198,5 (lungh.) x 138,5 (largh.) x 47,5 (alt.) mm	
Peso	400 g	
Connettore	Una porta Ethernet RJ-45, auto MDI/MDI-X 10/100 Mbps, auto-negoziante	
Antenna	Antenne interne con supporto per dual-band (2,4 GHz e 5 GHz)	
Distanza tra i centri dei fori (per il montaggio a muro) sul retro del dispositivo.	140 mm	
Tipo di viti consigliate per il montaggio a muro	Tasselli M4 (vedere la figura sotto)	

Temperatura d'esercizio	Da 0°C a 50°C
Umidità d'esercizio	Dal 10% al 90% di umidità relativa (senza formazione di condensa)
Certificazioni	EMC: FCC Classe B, CE-EMC Classe B, C-Tick Classe B, VCCI Classe B Sicurezza: CSA International, CE EN60950-1

Le seguenti sono le dimensioni di un tassello M4 e del tappo da parete utilizzato per il montaggio a muro. Tutte le misurazioni sono espresse in millimetri.

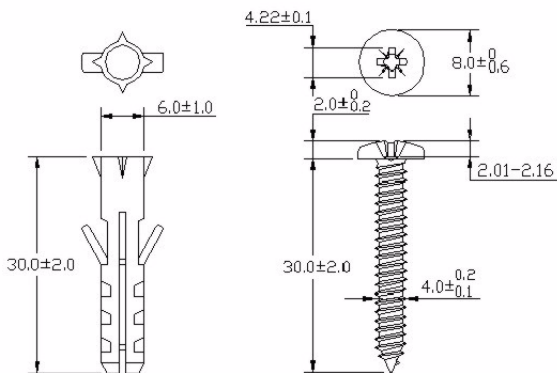

Procedura per visualizzare le certificazioni di un prodotto

1 Andare alla pagina www.zyxel.com.

- 2** Nel sito ZyXEL, selezionare il proprio prodotto dall'elenco a discesa per andare alla pagina di quel prodotto.
- 3** Da questa pagina selezionare la certificazione che si vuole vedere.

Вступление

NWA-8500 является точкой доступа, которая получает питание через контроллер БЛВС с функцией PoE (питание через Ethernet). NWA-8500 не требует использования сетевого адаптера или шнура питания. Вы можете просто подключить NWA-8500 к вашей беспроводной сети с беспроводным маршрутизатором с функцией PoE. Через NWA-8500 (отмеченный как **AP** на следующем рисунке), беспроводные клиенты БЛВС могут получить к сети Интернет или проводной сети.

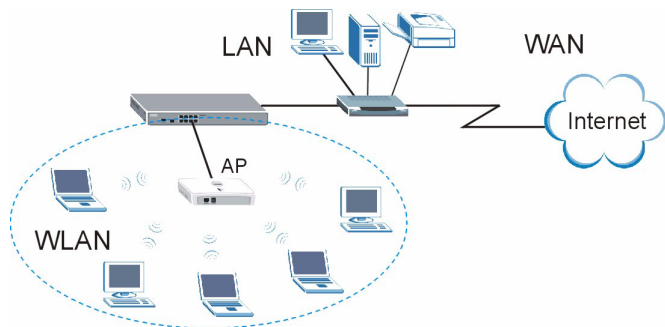

Это руководство покажет, как нужно подключать NWA-8500 к контроллеру БЛВС и закреплять ваш NWA-8500 на стене.

1 Подключение оборудования

Ниже приведены инструкции по настройке NWA-8500 для получения доступа к сети Интернет.

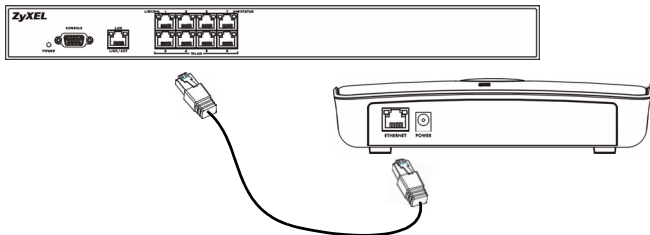

- 1 С помощью кабеля Ethernet подключите порт **ETHERNET** к порту **WLAN** контроллера БЛВС с функцией PoE. На момент написания руководства NWA-8500 можно подключить только к модели NXC-8160.

1.1 Светодиодные индикаторы

Посмотрите на индикаторы на NWA-8500.

Индикаторы **PWR**, **LAN**, **WLAN 1** и **WLAN 2** должны включаться при правильном подключении к порту Ethernet. При передаче данных индикаторы **LAN**, **WLAN 1** и **WLAN 2** будут мигать.

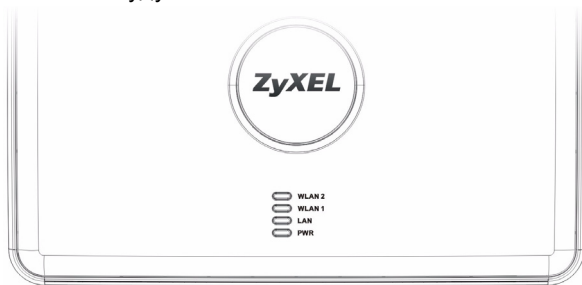

Если ни один из индикаторов не загорается, проверьте надежность подключений и состояние кабеля. Убедитесь, что ваш беспроводной маршрутизатор включен в сеть. Если индикаторы все еще не горят, то обратитесь к продавцу.

2 Монтаж оборудования

В общем, наилучшей точкой установки точки входа является центр зоны, в которой нужно обеспечить покрытие беспроводной сети. Для достижения наилучшей производительности установите NWA-8500 повыше, в свободном от препятствий месте.

2.1 Крепление на стену

Ниже приведены инструкции по креплению NWA-8500 к стене.



Смотрите [Характеристики изделия](#), где приведены размеры используемых винтов и расстояния между ними.

- 1 Расположите в верхней части стены, в свободном от преград месте.
 - 2 Просверлите два отверстия для винтов.
-



Будьте внимательны: не повредите кабели и трубы внутри стены при просверливании отверстий.

- 3 Не вкручивайте винты в стену полностью. Оставьте небольшой промежуток в 0,5 см между головкой винта и стеной.
- 4 Убедитесь, что винты плотно вошли в стену. Они должны выдерживать вес NWA-8500 с соединительными кабелями.
- 5 Совместите отверстия на задней поверхности NWA-8500 с винтами на стене. Подвесьте NWA-8500 на винтах.

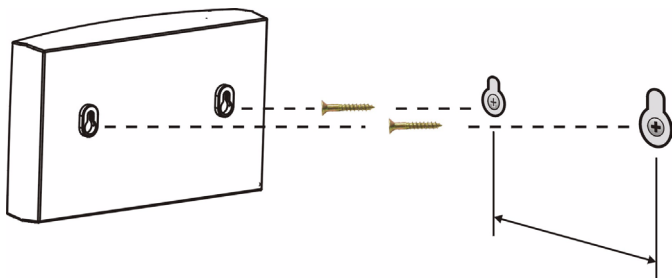

Характеристики изделия

Размеры	198.5 (Ш) x 138.5 (Г) x 47.5 (В) мм
Вес	400 г
Разъем	Один Ethernet порт 10/100 Мбс RJ-45 с разъемом MDI/MDI-X и автосогласованием
Антенна	Внутренние антенны с поддержкой двух полос (2.4 ГГц и 5 ГГц)

Расстояние между центрами отверстий (для крепежа на стену) на задней панели устройства.	140 мм
Рекомендуемый тип винтов для крепежа на стену	M4 Саморез (см. рисунок внизу)
Рабочая температура	0 C ~ 50 C
Рабочая влажность	10% ~ 90% относительной влажности (без конденсата)
Утверждено	EMC: FCC Class B, CE-EMC Class B, C-Tick Class B, VCCI Class B Безопасность: CSA International, CE EN60950-1

Ниже показаны размеры саморезов М4 и дюбелей, которые используются для крепежа к стене. Все размеры приведены в миллиметрах (мм).

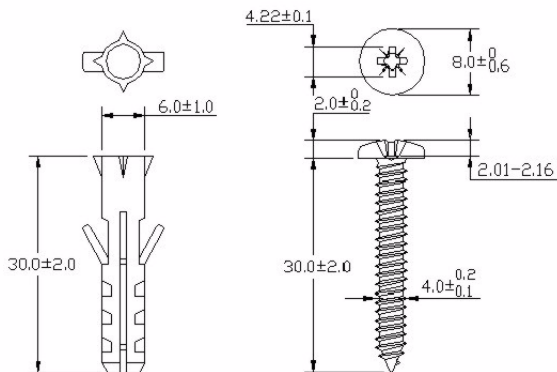

Процедура просмотра сертификатов изделий

- 1 Зайдите на сайт www.zyxel.ru.
- 2 Выберите нужное изделие из раскрывающегося списка на домашней странице корпорации ZyXEL и перейдите на страницу, посвященную этому изделию.
- 3 Выберите на этой странице в разделе "Для заказа" нужный сертификат для просмотра.

Introduktion

NWA-8500 är en åtkomstpunkt som får ström från en PoE (Power over Ethernet) WLAN-kontrollenhet. NWA-8500 behöver ingen strömadapter eller strömsladd. Du kan bara använda NWA-8500 i ditt trådlösa nätverk med en trådlös PoE-switch. Genom NWA-8500 (märkt **AP** i följande figur) kan trådlösa klienter i WLAN få åtkomst till Internet eller det stationära nätverket.

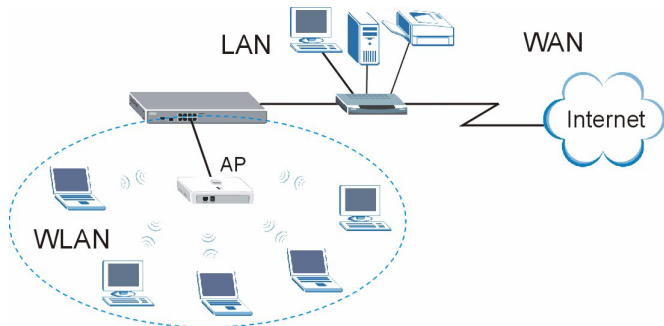

Denna guide visar hur du ansluter NWA-8500 till en WLAN-kontrollenhet och hänger upp NWA-8500 på väggen.

1 Maskinvaruanslutningar

Följ nedanstående steg för att ansluta NWA-8500 för Internet-åtkomst.

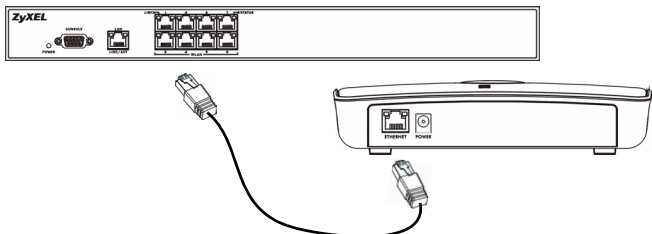

- 1 Använd den medföljande Ethernet-sladden för att ansluta porten **ETHERNET** till en PoE WLAN-kontrollenhets **WLAN**-port. När detta skrivs går det endast att ansluta NWA-8500 till modell NXC-8160.

1.1 Indikatorlampor

Titta på indikatorlampan(-orna) på NWA-8500.

Indikatorlamporna **PWR**, **LAN**, **WLAN 1** och **WLAN 2** är alla tända när Ethernet-porten är rätt ansluten. Indikatorlamporna **LAN**, **WLAN 1** och **WLAN 2** blinkar när det finns trafik.

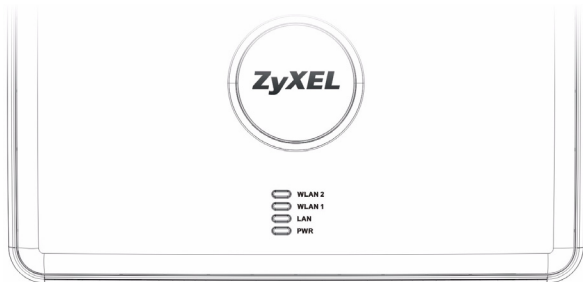



Om ingen indikatorlampa är tänd, kontrollera dina anslutningar och syna sladden då att den inte är skadad. Kontrollera att din trådlösa switch är påslagen. Om indikatorlamporna fortfarande är släckta, kontakta din återförsäljare.

2 Montera maskinvara

I allmänhet ligger den bästa placeringen för åtkomstpunkten i centrum av det avsedda trådlösa täckningsområdet. För bättre prestanda, montera NWA-8500 högt upp på en plats utan hindrande föremål.

2.1 Vägghmontering

Gör så här för att montera NWA-8500 på väggen.



Se [Produktspecifikationer](#) angående vilken skruvstorlek du ska använda och hur tätt de ska sitta.

- 1 Hitta en högt belägen placering på väggen, fritt från hinder.
 - 2 Borra två hål för skruvarna.
-



Var försiktig så att du inte skadar rör eller sladdar som är dragna inne i väggen när du borrar hålen till skruvarna.

- 3 Skruva inte in skruvarna hela vägen in i väggen. Lämna ett litet mellanrum på cirka 0,5 cm mellan skruvhuvudena och väggen.
- 4 Kontrollera att skruvarna är ordentligt fästa i väggen. De måste kunna bära upp vikten av NWA-8500 plus anslutningsladdarna.
- 5 Passa in hålen på baksidan av NWA-8500 med skruvarna i väggen. Häng NWA-8500 på skruvarna.

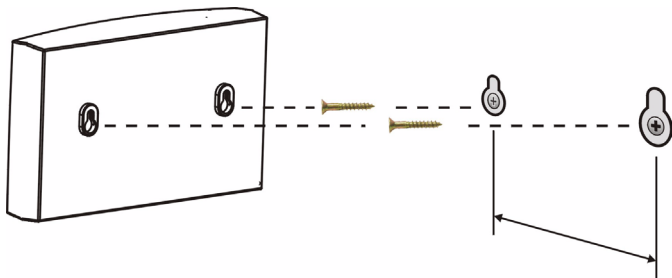

Produktspecifikationer

Mått	198,5 (B) x 138,5 (D) x 47,5 (H) mm	
Vikt	400 g	
Anslutning	En autoförhandlande, auto-MDI/MDI-X 10/100 Mbps RJ-45 Ethernet-port	
Antenn	Inbyggda antenner med stöd för dubbelband (2,4 GHz och 5 GHz)	
Avstånd mellan hålens centrum (för väggmontering) på enhetens baksida.	140 mm	
Rekommenderad skruvtyp för väggmontering	M4 tappskruv (se figuren nedan)	
Driftstemperatur	0° C ~ 50° C	
Driftsluftfuktighet	10 % ~ 90 % RH (icke-kondenserande)	
Godkännanden	EMC: FCC klass B, CE-EMC klass B, C-Tick klass B, VCCI klass B Säkerhet: CSA International, CE EN60950-1	

Följande är måtten för en M4 tappskruv och tegelplugg som används för väggmontering. Alla mått är i millimeter (mm).

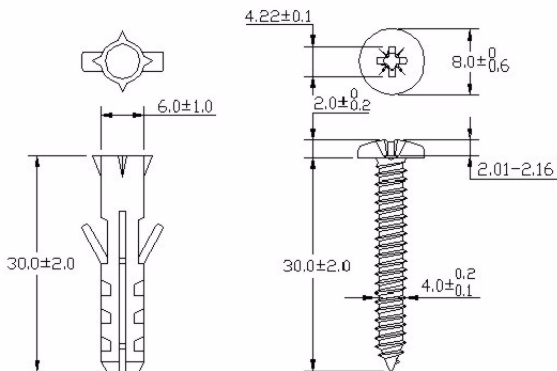

Procedur för att visa en produkts certifikat

- 1 Gå till www.zyxel.com.
- 2 Välj din produkt från rullgardinslistrutan på ZyXEL:s hemsida för att gå till denna produkts sida.
- 3 Välj det certifikat du vill titta på från denna sida.

För mer information och support besök www.support.zyxel.se.

介绍

NWA-8500 是一个从 PoE（以太网供电）WLAN 控制器接收供电的访问点。NWA-8500 不需要电源适配器或电源线。只需将 NWA-8500 与 PoE 无线交换机部署到无线网络中即可。WLAN 上的无线客户可通过 NWA-8500（下图中贴有 AP 标签）访问 Internet 或有线网络。

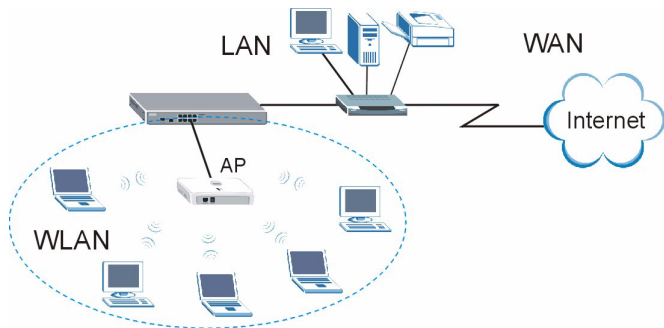

本手册讲解如何将 NWA-8500 连接至 WLAN 控制器，以及如何将 NWA-8500 安装在墙壁上。

1 硬件连接

按照下列步骤连接 NWA-8500，以便访问 Internet。

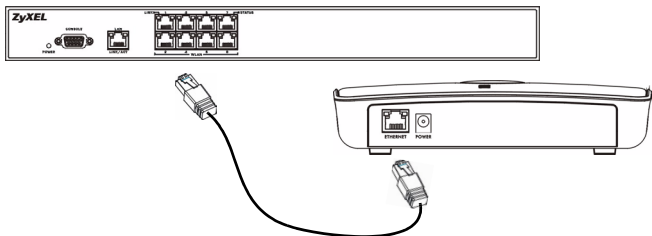

- 1 使用附送的 Ethernet（以太网）电缆将 **ETHERNET** 端口连接到 PoE WLAN 控制器的 **WLAN** 端口。至本手册编写时为止，只能将 NWA-8500 连接到 NXC-8160 型号。

1.1 LED（指示灯）

查看 NWA-8500 上的 LED（指示灯）。

正确连接至 Ethernet（以太网）端口时，**PWR**、**LAN**、**WLAN 1** 和 **WLAN 2** LED（指示灯）点亮。通信时，**LAN**、**WLAN 1** 和 **WLAN 2** LED（指示灯）闪烁。

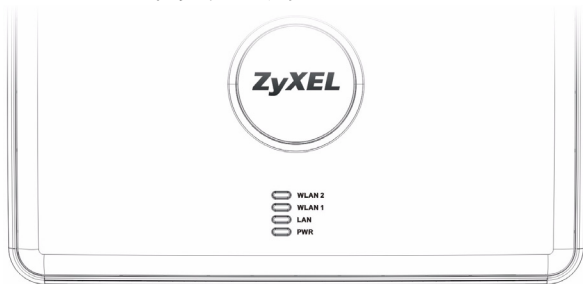



如果所有 LED（指示灯）均未点亮，请检查连接及电缆是否损坏。确保无线交换机开启。如果 LED（指示灯）仍未点亮，请联系供应商。

2 硬件安装

通常，访问点的最佳位置应为无线覆盖区域的中心。为获得更佳的性能，请将 NWA-8500 安装在不受阻碍区域的高处。

2.1 墙面安装

请按照下列步骤将 NWA-8500 安装在墙壁上。



查阅 [产品规格](#) 以了解使用的 螺丝钉的尺寸，以及螺丝钉之间的距离。

- 1 在不受阻碍的墙壁上找一较高位置。
 - 2 钻两个螺丝孔。
-



钻螺丝孔时请小心，以避免损坏安装在墙壁内的管道或线缆。

- 3 不要将螺丝钉完全拧入墙壁。在螺丝钉头部与墙壁间保留大约 0.5 cm 的间隙。
- 4 请确保将螺丝钉紧紧固定在墙壁上。螺丝钉需要承受 NWA-8500 及连接线的重量。
- 5 将 NWA-8500 背后的孔与墙壁上的螺丝钉对齐。将 NWA-8500 悬挂在螺丝钉上。

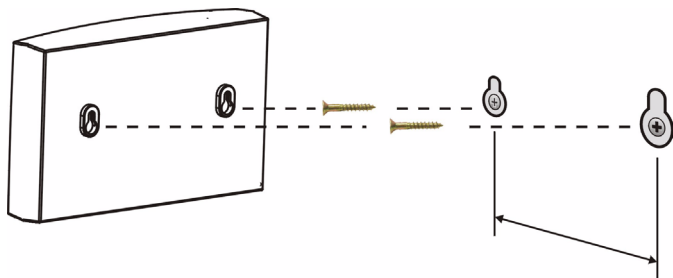

产品规格

尺寸	198.5 (W) x 138.5 (D) x 47.5 (H) mm	
重量	400 g	
连接器	一个自动协商、自动 MDI/MDI-X 10/100 Mbps RJ-45 以太网端口	
天线	内置天线，支持双频（2.4 GHz 和 5 GHz）	
设备背部孔（用于墙壁安装）中心间距	140 mm	
推荐的用于墙壁安装的螺丝钉类型	M4 自攻螺丝钉（参见下图）	

工作温度	0°C ~ 50°C
工作湿度	10% ~ 90% RH (无冷凝)
认证	EMC: FCC Class B、CE-EMC Class B、C-Tick Class B、VCCI Class B 安全性: CSA International、CE EN60950-1

下面是用于墙壁安装的 M4 螺丝钉和胀塞的尺寸。所有尺寸均以毫米为单位 (mm)。

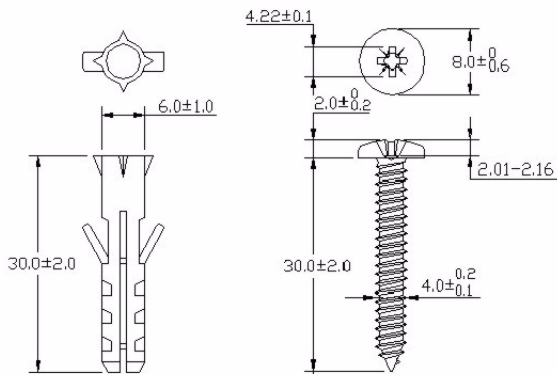

查看产品认证信息步骤

- 1 到 <http://www.zyxel.cn> 网站。
- 2 在合勤科技 (ZyXEL) 首页上的下拉式列表框中选取所要的产品, 跳至该产品的页面。
- 3 在页面中选取要查看的认证信息。

簡介

NWA-8500 為一基地台，從 PoE (乙太網路供電) WLAN 控制器接收電源。NWA-8500 並不需要電源配接器或電源線。您可用一台 PoE 無線交換器，將 NWA-8500 部署在您的無線網路中。透過 NWA-8500 (下圖中標示 AP 者)，在 WLAN 上的無線用戶就能接取網際網路或有線網路。

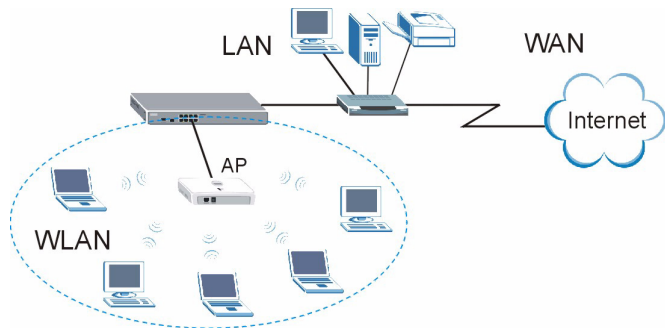

本手冊將介紹如何將 NWA-8500 連接至 WLAN 控制器，以及如何將 NWA-8500 掛在牆上。

1 硬體連接

依照以下步驟連接 NWA-8500 以接取網際網路。

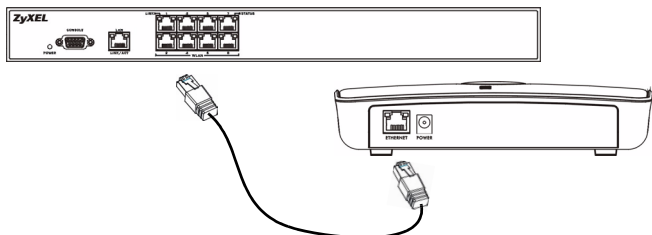

- 1 使用隨附的乙太網路線，將 **ETHERNET** 埠連接至 PoE WLAN 控制器的 **WLAN** 埠。在本文撰寫時，僅能將 NWA-8500 連接至 NXC-8160 機型。

1.1 LED 指示燈

請注意看 NWA-8500 上的 LED (指示燈)。

當乙太網路埠正確連接時，**PWR**、**LAN**、**WLAN 1** 及 **WLAN 2** 的 LED 指示燈全都亮起。有流量時，**LAN**、**WLAN 1** 及 **WLAN 2** 的 LED 指示燈閃爍。

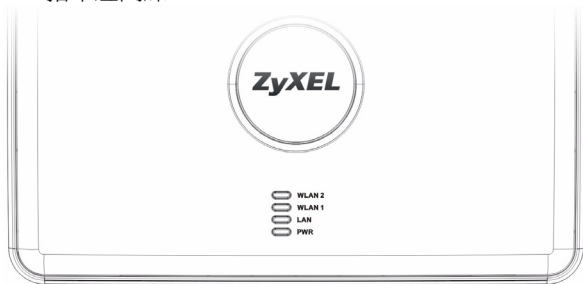



如果 LED 指示燈都沒亮，請檢查連線，並檢查纜線是否損壞。確認無線開關的電源開啓。如果 LED 指示燈仍然沒有亮，請聯絡當地的供應商。

2 硬體固定

一般而言，無線網路基地台最好的放置地點是無線網路覆蓋區域的中央。若要發揮較佳效能，請將 NWA-8500 安裝在高處沒有障礙物的地方。

2.1 壁掛式安裝

依照以下步驟將 NWA-8500 固定在牆面上。



參閱 [產品規格](#) 找出 所用的螺絲釘尺寸，以及螺絲釘的間距。

- 1 在牆上找出一個沒有障礙物干擾的高處位置。
- 2 鑽兩個孔給螺絲釘用。



在鑽螺絲孔時，請小心勿損傷到牆內的管線或纜線。

- 3 不要把螺絲釘全部旋入牆中，螺絲頭與牆面之間須留一小段大約 0.5 cm 的空隙。
- 4 確認螺絲釘已緊密的固定在牆上。它們必須支撐住 NWA-8500 及連接纜線的重量。
- 5 使 NWA-8500 背面的孔洞對齊牆面上的螺絲釘。將 NWA-8500 掛在螺絲釘上。

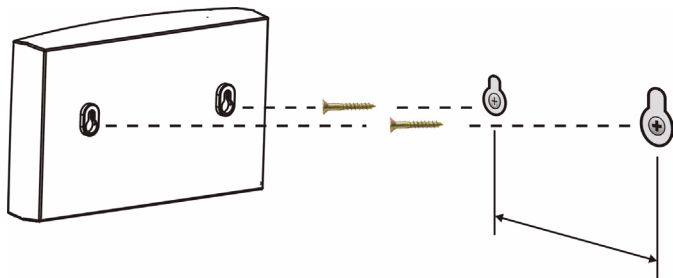

產品規格

尺寸	198.5 (W) x 138.5 (D) x 47.5 (H) mm
重量	400 g
連接器	一個自動協調、自動跳接 (auto MDI/MDI-X) 的 10/100 Mbps RJ-45 乙太網路埠

天線	內部天線支援雙波域 (2.4 GHz 及 5 GHz)	
在裝置背面上，圓孔中心（壁掛用）的間距。	140 mm	
壁掛式建議的螺絲釘類型	M4 攻絲螺絲釘（參閱下圖）	
作業溫度	0°C ~ 50°C	
作業溼度	10% ~ 90% RH（非凝結狀態）	
認可	EMC：FCC B 級、CE-EMC B 級、C-Tick B 級、VCCI B 級 安全性：CSA 國際部、CE EN60950-1	

以下為 M4 攻絲螺絲釘及壁掛式固定用泥水柱塞的尺寸。所有的測量單位是公厘 (mm)。

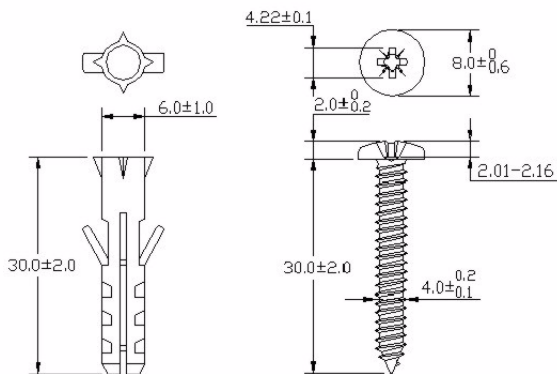

檢視產品檢定資訊步驟

- 1 到 <http://www.zyxel.com.tw/> 網站。
- 2 在合勤科技 (ZyXEL) 首頁上的下拉式清單方塊中選取所要的產品，移至該產品的頁面。
- 3 在頁面中選取要檢視的檢定資訊。